

OPERATING INSTRUCTIONS

Benkelman Beam

47-1460

<p>ELE International Chartmoor Road, Chartwell Business Park Leighton Buzzard, Bedfordshire, LU7 4WG England phone: +44 (0) 1525 249200 fax: +44 (0) 1525 249249 email: ele@eleint.co.uk http://www.ele.com ELE International, a division of Hach Lange Ltd.</p>	<p>Distributor:</p>	<p>ELE International Soiltest Product Division PO Box 389, Loveland, CO 80539 USA phone: +1 (800) 323 1242 fax: +1 (970) 663 9781 email: soiltest@eleusa.com http://www.eleusa.com</p>
<p><i>In the interests of improving and updating its equipment, ELE reserves the right to alter specifications to equipment at any time</i> ELE International 2009 ©</p>		

Contents

	Section	Page
1	General Information	3
2	Related User Documentation	3
3	Installation	3
4	Dial Indicator Installation	3
5	Operation	4
6	Calculations	4
7	Specifications	4
	Figure 1 : Benkelman Beam	5
	Figure 2 : Battery Wiring Diagram	6

1 General Information

The 47-1460 Benkelman Beam is a convenient, accurate device for measuring the deflection of flexible pavements under moving wheel loads. Operating on a simple lever arm principle, the unit consists of a Reference Beam Body, Two-Part Probe Beam, and Rear Zero Adjust.

The Benkelman Beam has the following user-friendly features:-

- Lightweight aluminium construction, allowing the user to easily transport the unit to any location.
- Unique telescoping design, simplifying field set up and reducing the amount of storage space needed.
- Vibrator system on dial indicators, assuring reliable pavement measurements.

2 Related User Documentation

These operating instructions do not contain all the required information on the test procedure to measure the deflection of flexible pavements under moving wheel loads. Please refer to AASHTO T-256 for more information.

3 Installation

3.1 Assembly

- 3.1.1 Carefully unpack the unit and inspect it for any evident damage. Report any damage/defects to ELE's Service Department immediately.
- 3.1.2 Remove the four probe beam locking studs from their storage position in the box, Figure 1, (5). Telescope the probe beams completely (pull out to full length) and lock into position with studs. Hand tighten.
- 3.1.3 Open the box cover, Figure 1, (5). Open the battery cover and install four "D"-size batteries, as shown on directions inside the battery compartment.

4 Dial Indicator Installation

The following instructions cover adjustments of the dial indicator.

- 4.1 Undo clamp screw, Figure 1, (2).
- 4.2 Turn the thumb wheel, Figure 1, (1), until the bottom of the levelling screw is about 4cm below the bottom of the frame.
- 4.3 Carefully install the dial indicator into the indicator collet, Figure 1, (3), loosening the collet nut if necessary. By looking through the window on the side of the frame, move the beam through its extreme up and down range. Watch the dial indicator as you move it. Set the dial indicator to coincide with the up and down movement of the beam as much as possible.
- 4.4 Note the relative position of the front "sensing" tip, Figure 1, (8), and the dial indicator pointer. If the front probe is not on the floor, loosen the lock nuts and screw the front levelling feet, Figure 1, (7), into their supports until the dial indicator is about in its mid range. Making sure the two levelling feet are an equal distance from the bottom of the frame, use the lock nuts to lock them in place. The dial indicator is now in its correct location, protected from bottoming damage.
- 4.5 **NOTE:** Before travelling with the Benkelman Beam the operator must remove the dial indicator from the indicator collet.

5 Operation

- 5.1 Place the unit 1.37m (4.5 ft.) behind the point of the pavement to be tested. Insert the probe beam between the dual tires of the vehicle, centring it so the tip of the probe rests on the test point.
- 5.2 Turn on the vibrator system, Figure 1, (4), and adjust the position of the rear support, Figure 1, (1), so the dial indicator is set at zero. Lock the rear support in place with its locking screw, Figure 1, (2). If additional adjustment is necessary, it can be done by repositioning the height of the front legs, Figure 1, (7).
- 5.3 Drive the test vehicle forward at the test speed, recording the maximum dial indicator reading as the vehicle advances.
- 5.4 After the vehicle has stopped (at approximately 7.62m or 25 ft. in front of the test point), record the final dial indicator reading.
- 5.5 Turn off the vibrator system.

6 Calculations

The 47-1460 Benkelman Beam has a lever ratio of 2:1. The dial reading will need to be multiplied by 2 for correct movement at the probe.

7 Specifications

Main Body	1,397mm (55") long, black finish aluminium
Probe Beam	Aluminium, 2.4m (8 ft.) long, telescopes into case for storage
Probe Fulcrum	Ball pivot bearing, gives lever ratio of 2:1
Vibrator System	Operating switch mounted on top of instrument section (requires 4 "D"-size batteries)
Levelling Wheel	Adjusts beams to proper elevation
Open Length	3.7m long
Weight	15.9 kg

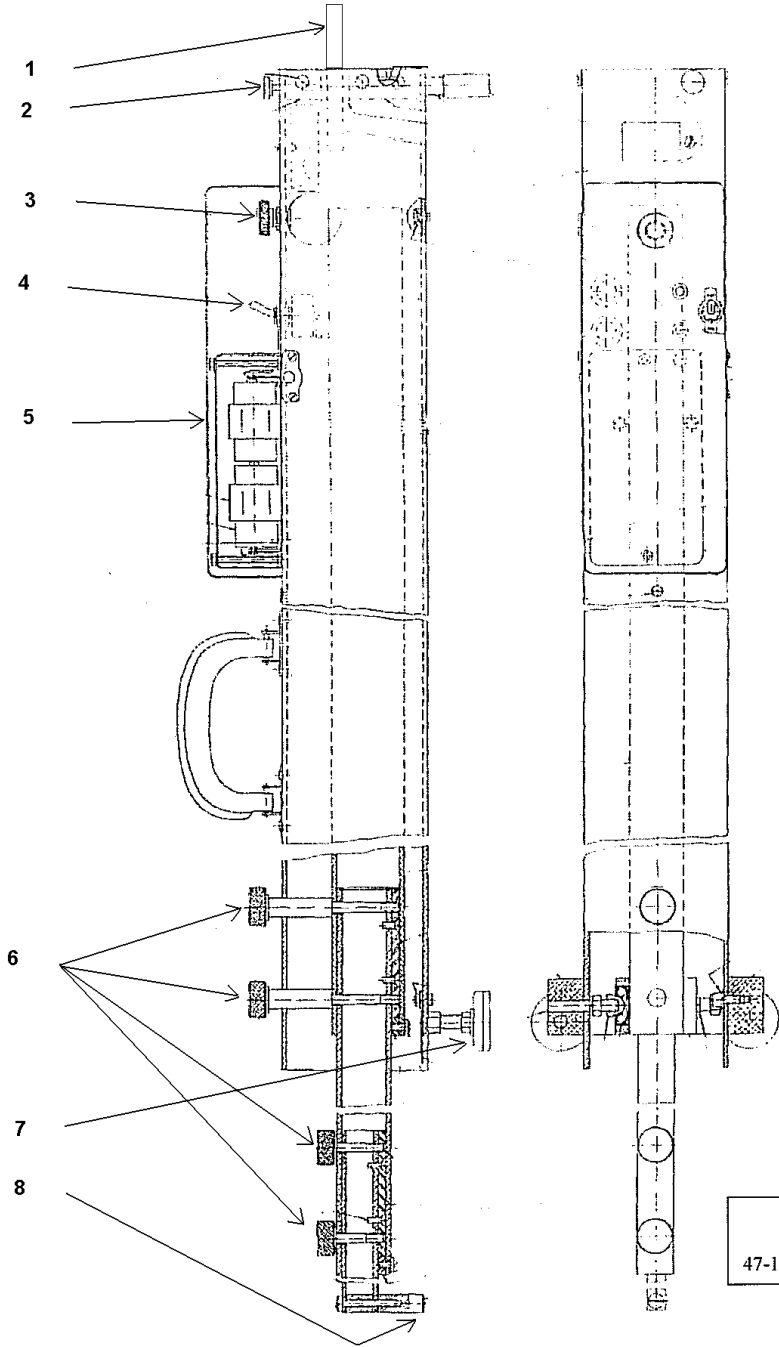

FIGURE 1
47-1460 Benkelman Beam

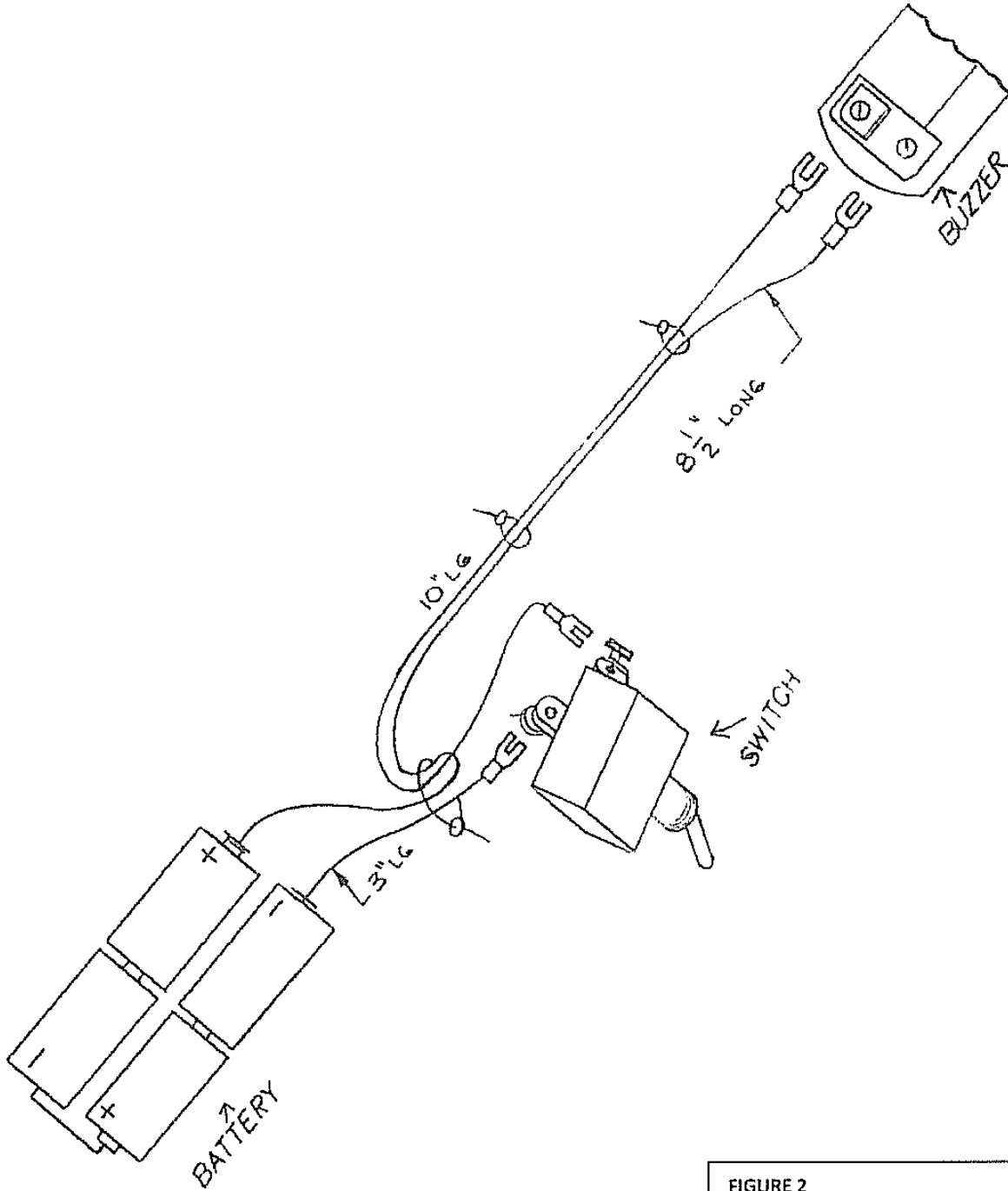

FIGURE 2
Battery Wiring Diagram